

METRO-LED SERIES II

LIGHTING TOWER

Performance

Height Stowed	2.40 m
Length Stowed	
Towbar in Transport Position	2.25 m
Towbar in Towing Position	2.90 m
Stowed Width	1.75 m
Weight GVM	1100 kg
Length with Outriggers Extended	2.34 m
Width with Outriggers Extended	2.15 m
Mast Max. Elevation	9.00 m
Wind Speed Rating	100 km/hr

Standard Specifications

Power

Engine	Kubota Z482
Fuel Type	Diesel
Fuel Consumption (litre per hour)	0.63 L/hr
Running Time (hours)	190+ hours
Generator	48 V DC
Lights	LED
Light Power	4 x 300W
Control System	Electronic Control
Noise Level @ 7m radius	< 60 dB(A)
Fuel Tank Capacity	125 L

Travel

Wheels	Sunraysia Style 14'x6J
Tyres	185R14C
Towing Speed (maximum)	80 km/ hr

Mast System

Lift	Hydraulic
Mast Lift Time	25 seconds
Mast Lower Time	13 seconds
Lighthouse Tilt	50° Electro Mechanical
Lighthouse Rotate	116° (+58°/-58°)
Hydraulic System Pump	
Voltage	12V DC
Pressure	240 bar (3500psi)
Flow Rate	0.78 cm ³ /rev
Function Control	Electric over Hydraulic

Standard Features

- External Emergency Stop
- Moulded Hoods
- Bundling for all Fluids (110%)
- Forklift Tyne Pockets
- Crane Lifting Point
- Folding Drawbar
- Long Extension Wind Down Outriggers
- 50° Light Head Tilt
- 116° Rotation of Light Head
- Torsion Independent Axle
- Cable Mechanical Disc brakes
- Sunraysia Style Rims
- LED Trailer Traffic Lights
- 7 Pin Flat Trailer Plug

Accessories & Options

- Upgrade Electronic Module including
- Auto-Start and Advanced Engine Management
- Battery Isolator Lockable
- Battery Isolator LockSafe
- Handbrake Mast Release
- Starter Isolator Lockable
- Starter Isolator LockSafe
- Spark Arrestor Muffler
- Burst Protection On Hydraulic Hosing
- Jump Start Receptacle
- Wheel Chocks
- Steel Hoods
- 4.5 kg Fire Extinguisher
- Rotating Amber Beacon or Strobe Light



This 9 m tower features 4 x LED lights on a 48 V 'extra low voltage' system and weighs just 1100 kg, enabling easy one person set-up. Designed and manufactured in Australia the Metro-LED tower SLL provides the value you need without sacrificing performance and quality you require.

METRO-LED SERIES II

LIGHTING TOWER

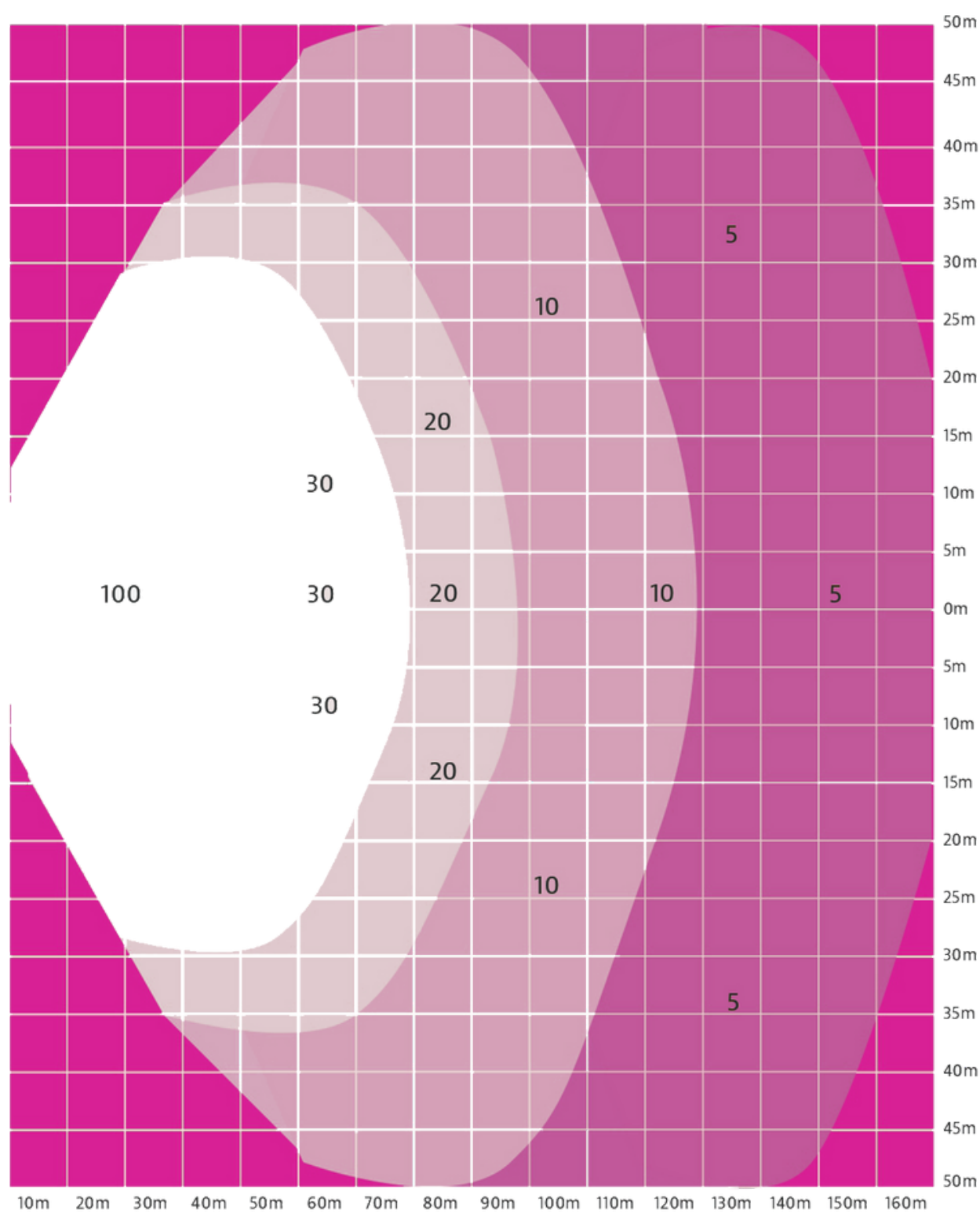
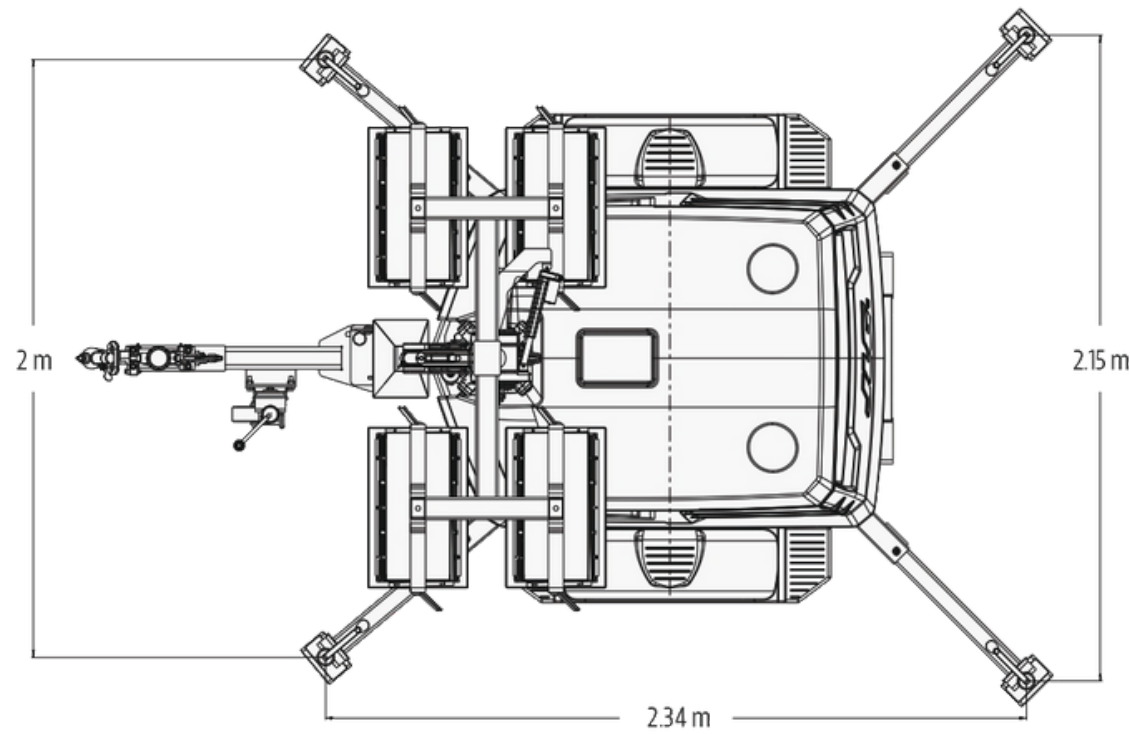

LGC
EQUIPMENT HIRE



1300 047 880



info@lgchire.com.au



www.lgchire.com.au